

Additional dimensional drawing **Separate mounting >10m**

R866891

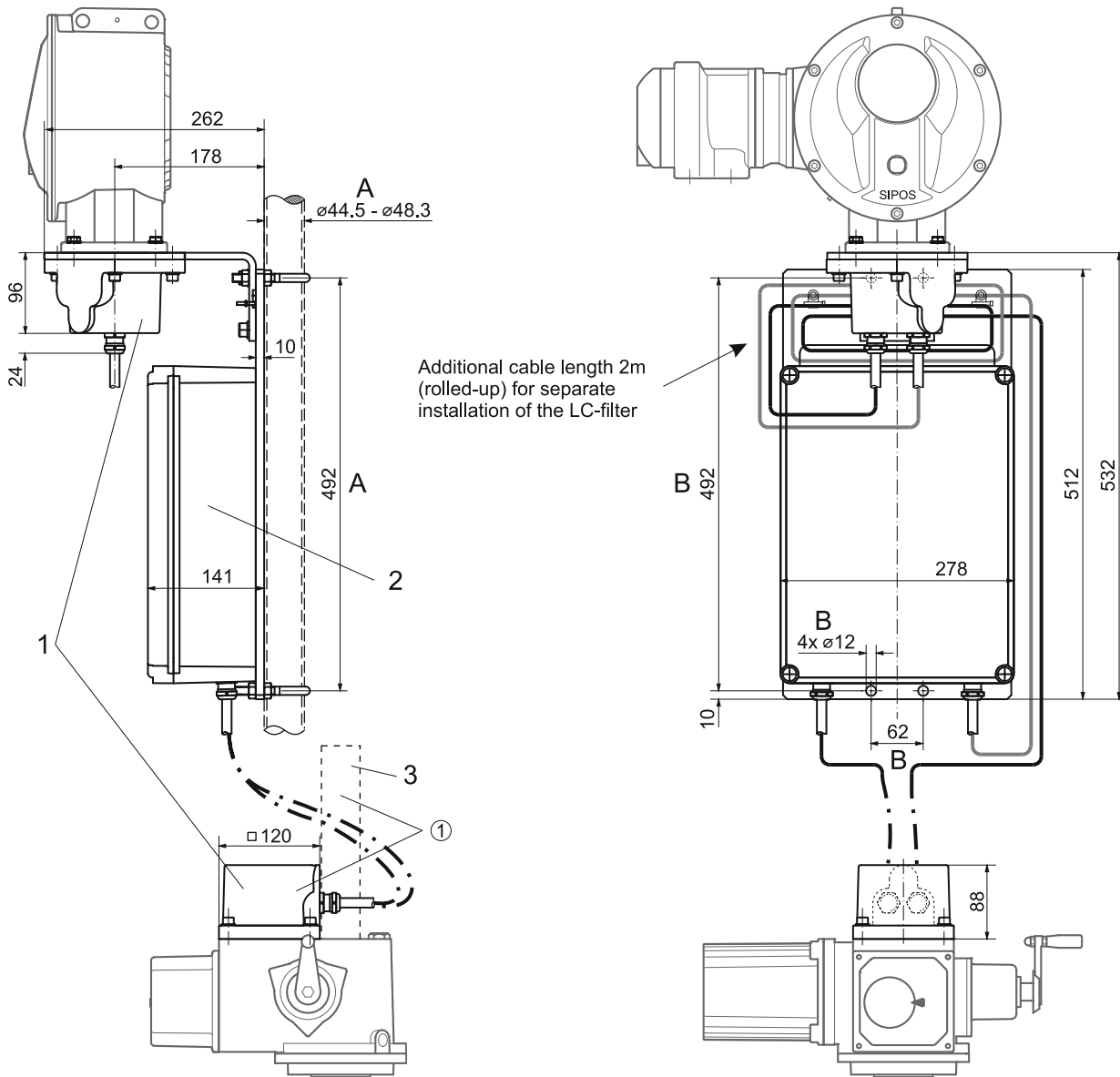

Missing dimensions refer to dimensional drawing

① For version with spindle protection tube, the plug element integrated into the connector hood has to be lifted by loosening the 4 fixing screws and inserted again shifted by 90° or 180°. The cable glands then point in direction of the motor or the position indicator.

**Caution:** Connecting cables must not touch the motor as the motor might become very hot at full load!

1 Connector hoods for separate mounting  
A Pipe mounting

2 LC-Filter  
B Wall mounting

3 Spindle protection tube (option)