

Maßbild **2SP7842, 2SP7843,**
2SP7853, 2SP7854

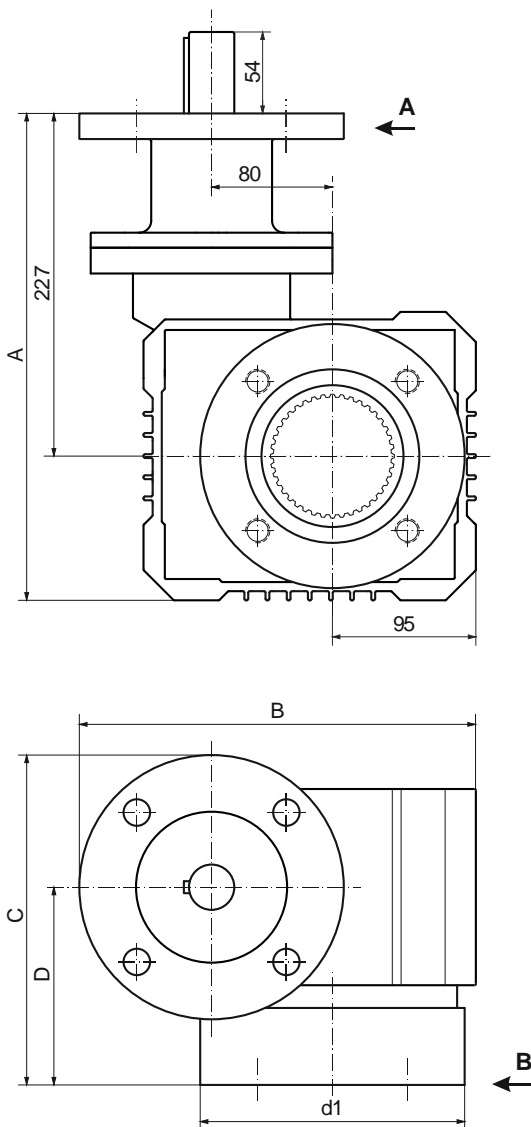

2SA7833-5 Flansch F14
2SA7843-5 Endwelle B3



Details A

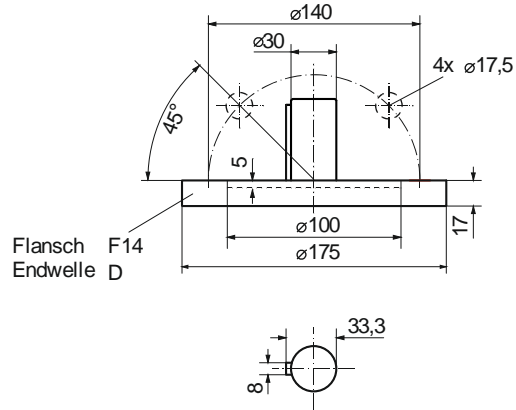

Details B

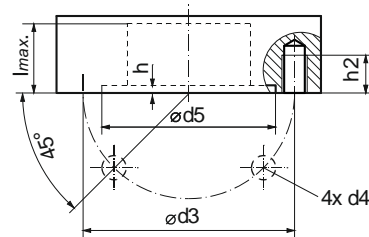

Maße	2SP784.		2SP785.	
	F12	F14	F14	F16
ISO 5211	F12	F14	F14	F16
A	323	323	323	332
B	263	263	263	273
C	208	219	219	239
D	120	131	131	151
$\phi d1$	150	175	175	210
$\phi d3$	125	140	140	165
d4	M12	M16	M16	M20
$\phi d5$	105	115	115	140
h	4	5	5	5
h2	19	25	25	32
l_{max}	58	68	68	88