

Dimensional drawing 2SB551., 2SB552.

R866706

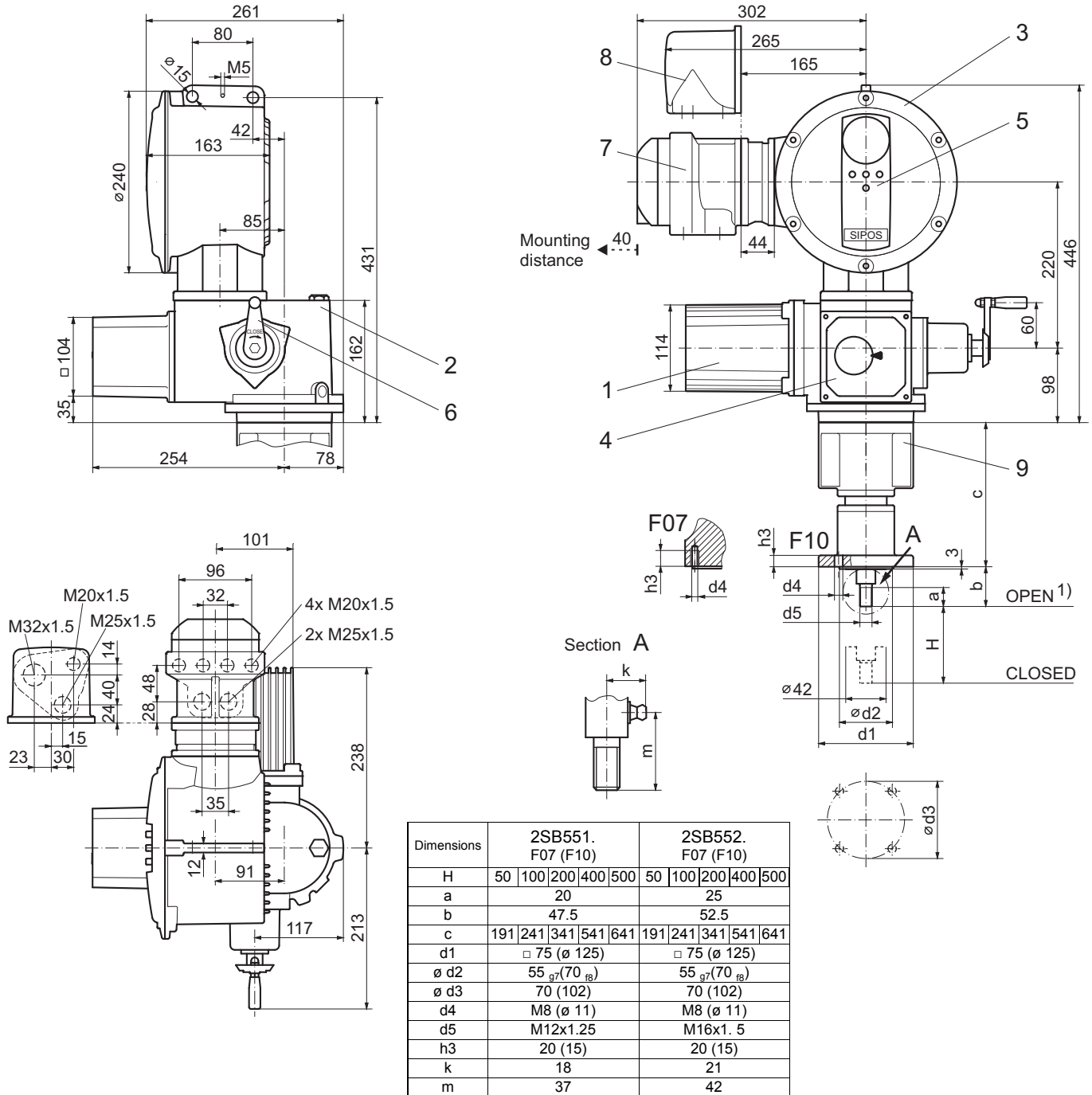

1) Hand crank: clockwise rotation
→ Driving rod extends

- 1 Motor
- 2 Basic gear
- 3 Electronics unit with converter

- 4 Signaling gear
- 5 Local control station
- 6 Hand crank

- 7 Field bus connection / Connection for galvanically separated analog signals
- 8 Direct-/ Plug connection
- 9 Linear stage