

Dimensional drawing **2SA783., 2SA784.-C**

R866862

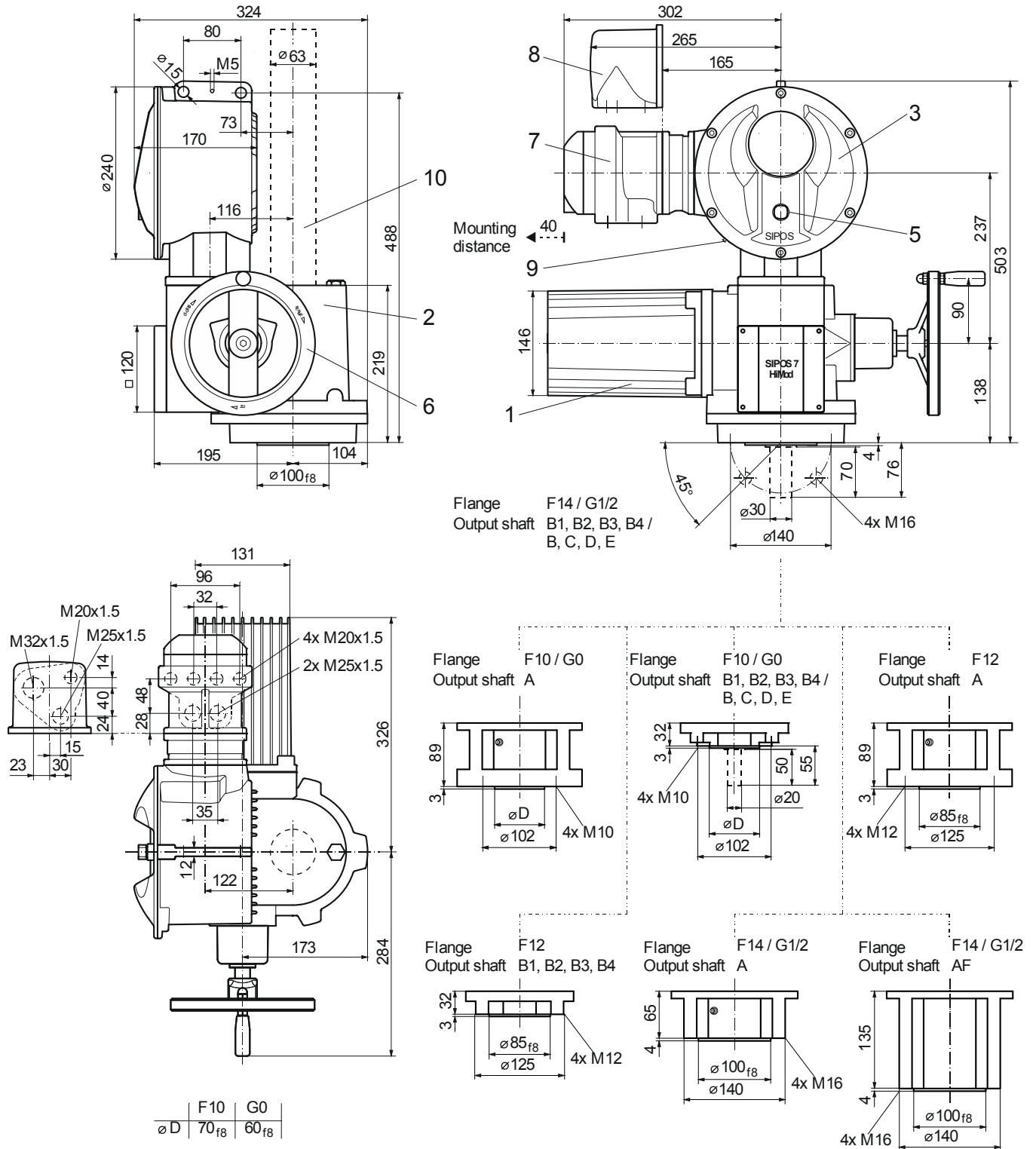

- |                    |                         |  |
|--------------------|-------------------------|--|
| 1 Motor            | 5 Local control station | 8 Plug connection                                    |
| 2 Gear unit        | 6 Hand wheel            | 9 USB interface                                      |
| 3 Electronics unit | 7 Field bus connection  | 10 Spindle protection tube (for length, see catalog) |