

SIPOS Solar

Solar system for SIPOS 5 Flash actuators

Instruction manual



Content	page
1 General	3
1.1 Safety instructions	3
1.2 General safety information	4
1.3 Disposal and recycling	5
1.4 Disclaimer	5
2 Transportation und storage	6
3 System components	6
3.1 Functional diagram	6
3.2 Description of basic components	6
4 Batteries	9
4.1 Safety instructions for batteries	9
4.2 Battery commissioning	9
4.3 Battery maintenance	10
4.4 Battery replacement	11
5 Installation	12
5.1 Safety instructions for installation	12
5.2 Solar module installation	13
5.3 Switching cabinet installation	14
5.4 Actuator installation	14
5.5 Cabling of the system	15
6 Commissioning	17
7 Operation	18
7.1 Energy storage	18
7.2 Emergency operation in case of system shutdown due to undervoltage	19
7.3 Procedure in case of system shutdown	19
7.3.1 Check of the fuses (F.) in the switching cabinet	19
7.3.2 Check of the RCD switch	19
7.3.3 Check in case battery protector has tripped	20
7.3.4 Check in case battery protector has not tripped	21
7.4 Cut off in case of emergency	23
8 Maintenance	23

1 General

We request you to read carefully the instruction manual in hand and to follow the contained recommendations, so that your systems runs trouble-free like you expect it to. The instruction manual is part of the Service Manual and should at all times be readily available near to the solar system.

If a malfunction or fault should occur, please consider that your service partner SIPOS Aktorik GmbH knows your system best. Sipos Aktorik is always interested that you are completely satisfied with the system purchased and will gladly support you in case of need.

1.1 Safety instructions

The following pictograms draw by appropriate definition attention to safety-relevant procedures in these operation instructions.

Safety instructions:



Warning marks activities which, if not carried out correctly, can affect the safety of persons or material.



Note marks activities which have major influence on the correct operation. Non-observance of these notes may lead to consequential damage.

Non-observance of the notes with safety may lead to serious injuries or damages.

Qualified personnel must be thoroughly familiar with all warnings and notes in these operation instructions:

Qualified personnel are persons who are authorized by the person responsible for plant safety, as a result of their training and experience as well as their knowledge of the applicable standards, regulations, accident-prevention regulations and operation conditions, to perform the respective tasks and to recognize possible hazards and prevent them.

Knowledge of first-aid and the local emergency services is also necessary.

In the case of heavy current plants, unqualified personnel are forbidden to carry out work by the regulations of e.g. DIN VDE 0105 or IEC 364.

Correct transport, proper storage, mounting and installation, as well as careful commissioning are essential to ensure a trouble-free and safe operation.

1.2 General safety information

The devices to which this document applies are components of installations which are designed for industrial applications. They are designed in accordance with the appropriate recognized technical rules.



It is assumed that the basic planning work for the installation, as well as all work involved in transport, assembly, installation, commissioning, maintenance and repair is carried out by qualified personnel resp. checked by responsible specialists.

It is particularly important to note:

- the technical data and specifications concerning the permitted use (installation, connection, ambient and operating conditions) which are included in the catalogue, order documentation, operating instructions, the details on the name and rating plate and the remaining product documentation,
- the general erection and safety regulations, especially the regulations concerning earthing and for lightning protection,
- the local, plant-specific regulations and requirements,
- the proper use of tools, lifting and transport equipment,
- the use of personal protective clothing.

For the sake of clarity, not all details of all versions of the product are described in these operating instructions, nor can they cover all conceivable cases regarding installation, operation and maintenance.

For this reason, the operating instructions only contain instructions that are necessary when the equipment is used for the purpose for which it is intended or in industrial applications for qualified personnel (see section 1.1).

In special cases, when the equipment is intended to be used in non-industrial areas, if more stringent requirements are applicable (e.g. protection against the penetration of children's fingers), these requirements must be met by the implementation of additional protective measures by the customer.

In the event of doubt, especially in cases of a lack of product-specific details, clarification must be obtained via your local SIPOS Aktorik sales department.

Please specify the type designation and works number in any correspondence (see actuator rating plate).

It is recommended that the services and support of the responsible SIPOS Aktorik service centers are utilized for all planning, installation, commissioning and service task.

We would also point out that the contents of these operating instructions and product documentation shall not become a part of or modify any prior or existing agreement, commitment or legal relationship.

The Purchase Agreement contains the complete and exclusive obligations of SIPOS Aktorik.

Any statements contained in this document do not create new warranties or restrict the existing warranty.

If the manufacturer of additionally mounted resp. installed components has generated and supplied special installation and operating instructions, these are enclosed with these operating instructions and must also be complied with.

This product is restrictively available according to IEC 61800-3 and may cause problems in domestic, environments.

In this case it may be necessary to take additional measures.



In this system voltages of up to 1000V can occur that can injure or be lethal in case of improper or incorrect installation, treatment or operation. Sever damage of property can also result. The safe contact with the system is only ensured by mounting and installation according to the instructions. Observe lightning protection regulations!



On various system components temperatures of up to 60°C can occur. Keep the components and their cooling units (ventilation slots, heat sinks and similar) clean at all times. Interference in the ventilation can lead to overheating and thus to failure. Never cover ventilation slots and heat sinks and do not put objects on them.

All work on the system, its erection and electrical connection must conform with national and local regulations. These can deviate from the here stated regulations. In doubt please check with the local authorities!

1.3 Disposal and recycling

- **Packaging**

Our products are protected by special packaging for the transport ex works. The packaging consists of environmentally friendly materials which can easily be separated and recycled.

For the disposal of the packaging material, we recommend recycling and collection centres.

We use the following packaging material

Wooden material boards (OSB) / cardboard / paper/ PE film.

- **Solar system**

The system components are made up of high-grade materials that almost all can be recycled. Units and accessories should be recycled environmentally friendly.



- Observe national/local disposal regulations.
- Please urgently observe the national regulations to the disposal of the system's batteries.

1.4 Disclaimer

Both the adherence to the instruction manual as also of the conditions and methods of the installation cannot be controlled. Thus we take no responsibility and liability for losses, damages or costs resulting from incorrect use and maintenance or are associated in any way.

SIPOS Aktorik reserves the right to change the product, technical data or instruction manual without prior notice.



Unauthorized interference on the system or operation which is not designated lead to loss of warranty! In case of problems admission from SIPOS Aktorik has to be obtained for repair or return of the system or components.

The system has been tested by the manufacturer and is not allowed to be modified in any way! Without approval of SIPOS Aktorik GmbH self-initiated repairs lead to loss of warranty. Observe the warranty regulations of the system components.

2 Transportation and storage

- Transportation equipment to the installation location in rigid packaging.
- Store in a dry, well-ventilated room.
- Protect against damp floors by storing on a shelf or palette.
- Handling solar modules needs great prudence:
 - Transport modules upright,
 - Carry modules with both hands, do not use the connection box as handle,
 - Avoid bending,
 - Do not lay on top of each other,
 - Do not weight, step on, drop,
 - Do not handle with pointed objects,
 - Keep electric contacts clean and dry,
 - It is recommended to note the serial nos.

3 System components

3.1 Functional diagram

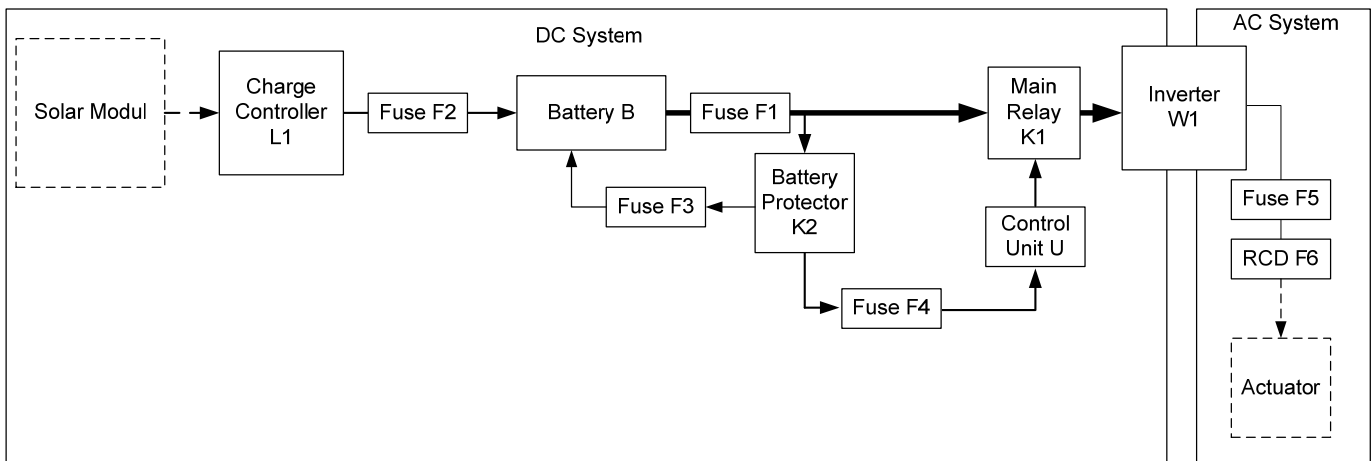

3.2 Description of basic system components



For the following system components the detailed technical documentation of the manufacturer can be found in the service handbook.

• Solar module

Depending on the system configuration and the site location high-quality solar modules from leading manufacturers are integrated to convert solar energy into electric energy. As the module selection varies depending on the site location and requirements, please see attached data sheet of the solar modules for technical data.

- **Charge controller (L1)**

The charge controller is the microprocessor controlled link between the solar modules and the battery. The charge controller works according to the MPPT method (Maximum-Power-Point-Tracking). The MPP is the point in the voltage-current diagram of a solar cell where the highest power can be extracted, i.e. the point where voltage and current are at the maximum. This point is not constant and depends on the irradiance, the temperature and the type of solar cell. With the MPPT method the maximum of the energy produced by the solar module can be stored in the battery. Furthermore by the life time of the battery is enhanced by the possibility of selecting the battery type.

- **Battery (B)**

Default delivery from SIPOS is with Solar-Gel-Batteries especially designed for use in solar applications. This lead-gel-accumulator is the storage cell of the energy transformed by the solar cell. In contrast to the usual lead-acid-accumulators the lead-gel-accumulators have following characteristics:

- totally maintenance-free and gastight,
- very low self-discharging,
- a wide working temperature range,
- high cycle stability,
- large discharge depth and
- long lifetime.

- **Battery protector (K2)**

The battery protector is situated between the battery and the consumers. It protects the battery from dangerous deep discharge and the consumers from over and under voltage.

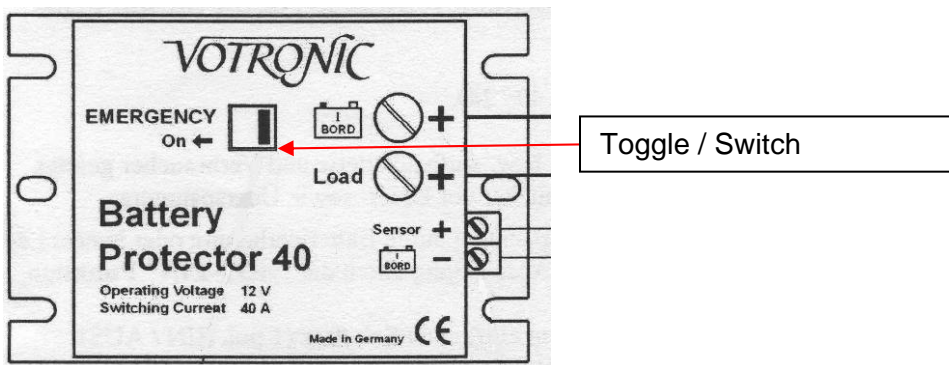

The battery voltage is measured via the sensor leads. If the battery voltage is out of the acceptable range, the integrated relay switches off and separates the battery from the consumers.

A switch-off occurs:

- automatically at deep discharge (undervoltage) after more than 10 seconds.
- automatically at overvoltage after more than 10 seconds.
- manually toggling the switch (EMERGENCY) in direction "BORD".
In this case switching on must also be performed manually.
- by switching off fuse (F3) in the sensor line. (Main switch resp. emergency switch-off function).



If the system is switched off via the battery protector, the charge controller is still connected to the battery. In case no re-charging is performed the battery can be deeply discharged.

A switch-on occurs:

- automatically after deep discharge after battery recovery/ battery charge.
 - automatically after over voltage when voltage sinks.
 - manually through toggling the switch (EMERGENCY) in direction "On".
- However if the battery voltage sinks through the load of the consumers again, the unit switches off again!



In the interest of a high battery lifetime this action should not be repeated unnecessarily often!

- **Control unit (U)**

The control unit incorporates the controller of the connected actuators. This unit is designed customer specifically for the system and is described in the supplement instructions „control unit “ and can be found in the service handbook.

- **Inverter (W1)**

The inverter transforms the DC battery voltage into sinus AC voltage. Voltage controlled the inverter provides quartz-controlled precise AC voltage. The inverter serves as voltage supply for the SIPOS 5 Flash actuator that is connected via a protective circuit.



- The inverter as also the complete system is designed for the connection of the designated consumers. The connection of consumers other than the originally intended can lead to damage of persons or parts of the system! Connection of not designated consumers leads to loss of warranty!
- All work on the unit, it's mounting and electric connection have to be performed in conformance with the national and local regulations. These can deviate from the regulations mentioned here. In case of doubt, contact the local authorities!

- **Fuses (F.)**

The fuses F. serve as protection against over current and short circuit protection. The RCD is a so called ground fault circuit interrupter. It serves as protection against error current and especially for personal protection.

- **Actuator**

The SIPOS 5 Flash actuator is the main component of the system. The solar system serves for the automation and energy supply of the actuator. The functionality of the actuator is manifold and is described in detail in the actuator instruction manual delivered with the actuator. It contains details information for commissioning, operation and maintenance.

4 Batteries

4.1 Safety instructions for batteries

Handling batteries special safety instructions are to be observed:



- Observe instructions and fix visible to loading berth. Follow notes on the battery.
- Work on the batteries only after instruction by qualified personnel.



- When working on the batteries use protective glasses and clothing.
- Follow the accident prevention regulations DIN EN 50272-3, DIN EN 50110-1.



- Keep children away from acid and batteries!



- Smoking prohibited.
- No open flames, embers or sparks near the battery due to explosion and fire danger.
- Avoid spark formation when working with cables and electrical devices as also electrostatic discharge.



- Wash out acid splashes in the eye or on the skin with large amounts of water. Then immediately consult a doctor.
- Wash acid contaminated clothing with large amounts of water.



- Explosion and fire danger, avoid short circuits.
- Attention! Metal parts of the battery cells are always energized thus do not place parts or tools on the battery.
- Rings, watches and clothing with metal parts that can come in contact with the poles of the batteries should be taken off.



- Electrolyte is extremely corrosive.



- Do not tilt battery.
- Block batteries are heavy. Use only approved lift and transport equipment. Lifting hooks are not to damage cells, connectors or connecting cables.
- Do not submit batteries to direct sunlight.
- Discharged batteries can freeze, thus store frost-free.



- Dangerous electrical voltage!



- Observe the dangers emanating from batteries.

4.2 Battery commissioning

The batteries should be checked to ensure that they are in perfect condition.

Please check:

1. The cleanness of the batteries and the battery storage.
2. The battery connectors are connected with secure tightness and correctly poled. Else the battery or parts of the system can be damaged or accidents can occur. The required torque for the pole connectors is 14 - 20 Nm.
3. Default delivery from SIPOS is with Solar-Gel-Batteries. These batteries are absolutely maintenance-free.
4. The nominal temperature is 30°C. Higher temperatures reduce the battery lifetime, lower temperatures reduce the available capacity. The operating temperature range is specified on the data sheet supplied with the battery.

4.3 Battery maintenance

Charging: The battery is normally charged via the charge controller of the system. If the battery is charged with an external battery charger, the battery has to be disconnected completely from the system. When using an external charger, urgently observe the safety regulations. Default delivery from SIPOS is with Solar-Gel-Batteries. These batteries have special requirements concerning the charging. To avoid damaging the battery, a special charging device for Solar-Gel-Batteries is to be used. SIPOS Aktorik is happy to support you to select the suitable battery charger. If the system is not used all year round (seasonal operation) it is recommended to remove the battery and to store it in a dry, frost-free room. Storage is recommended to max. 6 months at 20°C without charging. To ensure operational readiness the battery can be kept at optimal charge status attached to a suitable battery charger.

Maintenance: The battery should be checked and serviced every 6 months to ensure operational readiness. Default delivery from SIPOS is with Solar-Gel-Batteries. This type of batteries is completely maintenance-free. That means that deviating from lead-acid batteries it is not necessary to refill them with distilled water or to determine the electrolyte density.

Never open the battery!

Check procedure:

1. Visual check

- no external damages (cracked housing, etc.)
- battery and battery housing free of contamination
- no short-circuit traces on the battery poles
- connecting cables are in perfect condition (no detectable corrosion, isolation without damages)

2. Voltage check

Check off-load voltage (U_0) with voltmeter or battery tester (without load resistors and without connected consumer loads) to obtain an overview of the load status of the battery:

The off-load voltage is influenced by the battery capacity and the ambient temperature. Thus the off-load voltage is only an indicator for the charge status. Important hereby is that the battery is measured at a constant ambient temperature of approx. 20-25°C.

Also the battery should be kept at least for 5 hours in the open circuit, so that the charge voltage can deteriorate and the off-load voltage can be measured.

To determine the approximate battery capacity following values can be consulted:

Off-load voltage	Charge status
> 12.9 V	100%
~ 12.6 V	75%
~ 12.3 V	50%
~ 12.1 V	25%
~ 12.0 V	0%

3. Load test

With a load test it is possible to determine a possible defect of the battery. To conduct such a test, the battery must be charged ($U_0 > 12.7V$).

The battery should be loaded with following currents:

Battery type	Test current	Load voltage
from 75 – 90 Ah	200 A	> 9.5V
from 120 – 145 Ah	300 A	> 9.5V

As the adjustable range of these testers are correlated to starter batteries, following deviating capacity values are to be set:

Battery capacity Gel-Battery x 0.55 = Setting on the tester

(e.g. Capacity Gel-Battery 90 Ah x 0.55 = 44 Ah on the tester).

If the load voltage is higher than 9.5V the battery is OK. If the load voltage is lower, the battery is defect or has to be re-charged.

4.4 Battery replacement

The battery is a component with a limited life time. If the battery is defect or does not meet the requirements of the system, it should be replaced.

SIPOS Aktorik recommends to use a closed, gas-tight, maintenance-free Solar-Gel-Battery with the same system voltage and the same capacity (Ah).



- When using Lead-Acid-Batteries it can come to outgassing of the battery. This aggressive gas can destroy electronic components in the switching cabinet. When using unsuitable batteries, the warranty is void.
- **Collection and disposal of used batteries according to battery regulation (BattV)**
Used batteries are especially to be monitored waste to be recycled. The batteries with the recycling sign and the crossed out refuse bin on it are not to be put into domestic waste. The type of collection and recycling is to be determined acc. to § 8 BattV with the manufacturer.
- Please urgently observe the national regulations to the disposal of the batteries.

5 Installation

5.1 Safety instructions for installation



- Safety instructions for the solar gel battery can be found in the chapter „safety instructions for batteries“ and have to be observed!
- Danger to life by electric shock!
Solar modules produce electricity as soon as they are subjected to light and are always energised.
- Never connect or disconnect the solar cables of the solar modules under load!
Electric arcs can be generated that are a danger to persons. Switch off load before work!

A single module lies under the protection threshold for small voltages, however several modules in series (summation of the voltages) or in parallel (summation of the currents) represent a danger. When handling solar modules observe the following to avoid fire, spark formation and deadly electric shock:

- Cover solar modules if possible before connection the solar cables (protect against sunlight)!
- Do not introduce electric conducting parts into the plugs and sockets!
- Do not mount solar modules and cables with wet plugs and sockets!
Tools and work conditions should be dry!
- Perform all work on cables with extreme caution and use safety equipment (isolated tools, isolated gloves, etc.)!
- Do not use damaged modules! Do not dismantle modules!
- Do not remove attached parts or manufacturer name plates!
- Do not apply backside with paint, adhesives or pointed objects!

Observe local regulations for erection and accident prevention when mounting the system.

The safety instructions of other system components have to be followed.

Pay attention that persons working in a certain height have to be secured and protected against fall. Persons on the ground have to be protected against falling objects by barriers.

For roof mounting the engineering rules especially national and international norms as also local regulations have to be observed.

5.2 Solar module installation



- Pay attention to the compliance to the max. permissible load according to IEC 611215 considering the loads depending on the location by e.g. wind and snow.
- Earth solar module (recommendation!)
- Protect module from lightning!
We recommend to provide for lightning protection acc. to established norms.
- No damaging mechanical or electric impact may be exerted on the module through other system components.

• Orientation and inclination of the solar module

To achieve the optimal yield in the months with the least sunlight, we recommend to follow the determined inclination angle and orientation stated in the document „dimensioning data of the solar system“. Sunlight hitting the solar module in a right angle represent ideal conditions for electricity production. When modules are connected in series, the modules should have the same angle and orientation to avoid output losses.

The dimensioning data are a separate document in the service handbook.

• Shadowless insolation of the solar module

Even the smallest partial shadowing (e.g. through dirt) lead to yield losses. A module is defined as “shadow-free”, if, for the defined operation period, the module itself is completely unshadowed and unhindered insolation is possible for several hours even on the calendarically worst days.



The solar system is dimensioned for a shadow-free location.
Shadowing can lead to system failure!

• Mounting of the solar module

As the mounting of the solar modules depends on the site and location, no particulars are given in this instruction manual to the mechanical mounting of the solar modules. The mounting type (mast, roof, etc.) is described in the system specific document „Utilised system components“ of the service handbook.

Installation of the mounting system is to be performed according to the mounting instructions of the supplied system.

• Reliable backside ventilation of the solar module

A well functioning backside ventilation avoids yield impairing heat accumulation and benefits drying of precipitation water and condensate.

On the backside of the module are holes for drainage of precipitation water.

Pay attention that these holes are not hindered in their function by the mounting system.

- **Earthing of the solar module**

The earthing can be performed directly on the frame or on the mounting system, if the frame is connected in a conductive way.



- The earth connection must be performed by qualified personnel!
- The earthing must be performed before cabling the system!

For earthing cables (16 mm²) with ring terminals are to be used. A prebored through boring (diameter 4mm) exists in the frame of the solar module for the connection of the earthing cable. To establish a conductive connection (frame is anodised) use a screw (M4) and a contact disc.

- **Lightning protection for the solar system**

To protect the solar system from lightning strikes a lightning protection is recommended.



- The lightning protection must be implemented by qualified personnel!
- The lightning protection must be implemented before cabling of the system!

Mounting of a solar module on a building or device already equipped with lightning protection requires inspection by appropriately qualified personnel, if by additionally mounting of a solar module, the lightning protection of the building and the solar module is assured.

5.3 Switching cabinet installation

Following is to be observed when mounting the switching cabinet:

- **Place of installation of the switching cabinet**

- Install switching cabinet as near as possible to the solar modules

This reduces power losses.

In general the solar system should be installed as near as possible to the application.

More important however is to choose the optimal location concerning insolation. The cable length from the switching cabinet to the actuator is not as important.

- avoid direct sunshine

When installing the switching cabinet it is important to avoid direct sunlight. This intensifies the ambient temperature of the implemented components. The ambient temperature should not be over 40°C.

- protect from direct atmospheric exposure

The degree of protection of the switching cabinet is IP 56. For installation outdoors the switching cabinet should be protected by constructional measures (e.g. small roof) from rain, hail and snow.

- **Mounting of the switching cabinet**

Mounting is performed on the backside of the switching cabinet. The switching cabinet should be mounted in a suspended way.



Mounting of the switching cabinet must be performed by appropriately qualified and authorised personnel. Safety and accident prevention regulations must be observed!

5.4 Actuator installation

Installation and commissioning are described in detail in the instruction manual of the actuator which must be observed and which can be found in the service handbook.

5.5 Cabling of the system

It is recommended to perform the cabling of the solar system according to following list.



The cabling is to be performed by qualified and authorised personnel!



All cables must be inserted via cable glands from the bottom side of the switching cabinet!

• Joint cabling of several solar modules

If the solar system includes several solar modules, the cabling of the solar modules among each other must be performed before the solar cable enters the switching cabinet.



- When connecting several solar modules, first connect the modules according to the wiring diagram to an array, then check the wiring and in the final step of the cabling of the whole system, perform the connection from the switching cabinet to the array!
- If the solar modules are incorrectly connected, the system cannot work properly and system components can be destroyed!

When cabling several solar modules pay attention to the following:

- Correct wiring according to the wiring diagram (attached to service handbook)
When cabling avoid loops (risk reduction in case of indirect lightning strike)



To reduce voltages by lightning strikes, the area of all conductor loops must be as small as possible!

- Correct clamping and pole-correct connection

When clamping the connection cables, use only the provided material. Pay attention to correct clamping to avoid contact resistances.

The solar module must be connected pole-correct:

positive cable (+) = red cable,
negative cable (-) = black cable.

- Cable protection and fixation

Protect exposed cables from damage by suitable measures (e.g. plastic tubing).
Fasten the cables with UV-resistant cable binders to the mounting system.

• Earthing of the solar system



To protect persons from electric shock and to protect structures and persons from lightning strike an earthing concept is compulsory!

Earthing concept:

1. Connect earthing cable of the solar modules to grounding (recommendation!)
2. Connect switching cabinet via earthing cable (16mm²) to grounding. The earthing cable must be connected to a green-yellow earthing clamp.
3. Also connect the earthing cable of the actuator to a green-yellow earthing clamp.

- **Connection of the actuator**

It is recommended to first connect the power supply cable on the actuator side and then in the switching cabinet. It is also recommended to perform the actuator connection before the battery connection to avoid danger by high voltages.

- Connection on the actuator side:
The connection is described in detail in the instruction manual and the attached wiring diagram.
- Connection on the switching cabinet side:



- To avoid danger the fuse (W1) of the inverter must be turned off.
- Before connection validate that power is off!

1. Enter connecting cables from the bottom side of the switching cabinet.
2. Connect cables. (for connection terminals see wiring diagram).
3. Pass connected cables through cable duct.
4. Tighten cable glands.

- **Connection of the solar gel battery**



Urgently observe safety instructions to the solar gel battery (see chapter „safety instructions for batteries “)!

Connect battery pole correctly with the provided screws and the appropriate torque (14-20 Nm):

- positive pole (+) = red cable,
- negative pole (-) = black cable.

- **Connection of the solar cables (connection cable from switching cabinet to solar module)**

It is recommended to first connect the cables on the switching cabinet side and then on the solar module.

- Connection in the switching cabinet:
 1. Insert solar cable from the bottom side into the switching cabinet.
 2. Connect cables. (for terminals see wiring diagram):
 - positive cable (+) = connect red cable to terminal X1.1
 - negative cable (-) = connect black cable to terminal X1.2
 3. Pass connected cables through cable duct.
 4. Tighten cable glands

- Connection on the solar module:
When connecting the solar cables to the solar modules pay attention to following:

1. Correct connection acc. to wiring diagram (see service handbook)
Avoid loops when connecting (risk minimising for indirect lightning strike).



To avoid voltages through lightning strikes, the area of all cable loops must be as small as possible!

2. Correct clamping and pole correct connection
Use the provided material for clamping of the solar cables. Pay attention to correct clamping to avoid contact resistances.
The solar modules must be connected pole correctly:
 - positive cable (+) = red cable,
 - negative cable (-) = black cable.
3. Cable protection and fixation
Protect exposed cables from damage by suitable measures (e.g. plastic tubing).
Fasten the cables with UV-resistant cable binders to the mounting system.

6. Commissioning

To be able to check the correct and complete functionality of the system, the solar module should be insulated, as in case of bad weather or darkness only a small or no charge current flows.

The commissioning is to be performed in following steps:

1. Switch on main fuse F1.
2. Switch on fuse F2. Now the charge circuit for charging the battery B is ready.



If sufficient solar power is available, the yellow LED “charge” of the charge controller L1 is lighted and the charging begins. The green lighted LED indicates that the battery is fully charged. The red LED indicates a low charge level of the battery.

3. Switch on battery protector K2. To do this the fuse F3 in the sensor circuit of the battery protector must be switched on. The monitor relay is activates and releases the control circuit.
4. Switch on fuse F4, providing the controller unit with power.
5. Commissioning controller unit.



The commissioning of the controller unit is described in the supplement instructions “control unit“!

6. Switch on the DC fuse of the inverter W1 and turn the potentiometer on the bottom side of the inverter clockwise until the end stop for standby detection. Thus the inverter is set to continuous duty. If the inverter is supplied with power, the green LED on the bottom side is permanently on.



The output of the inverter W1 now supplies high AC voltage!

7. Switch on fuse F5 and RCD. Thus the actuator is supplied with power.



To provide sufficient operator protection the function of the RCD must be checked by an authorised and qualified expert!



The commissioning of the actuator is described in the instruction manual of the actuator and if applicable in a supplement instruction!

7 Operation

Solar system for the stand-alone operation of electric actuators depend on the requirement profile of the customer, thus from the design specifications and the site conditions.

The solar system was designed specifically for one site and energy consumption in a customer specific application.

The valve used by the customer determines the selected actuator concerning mechanical interface, torque and output speed.

Quantity and rating of the solar modules is determined by the power (energy requirement) of the actuator, the location, the operational period and the active duration per day.



Deviation to this precisely specified load behaviour can result in failure of the power supply and in the worst case lead to destruction of system components of the solar system.

The dimensioning data of the solar system are a separate document in the service handbook.

7.1 Energy storage

Energy storage is understood as the continued provision of the required energy for a limited duration.

The system dimensioning refers to the statistical average of the month with the least sunshine in the considered operation period. The solar insolation of a site averaged over a month is relatively constant and can be used as basis for dimensioning solar systems.

For longer lasting good weather periods, in which the energy provision by insolation is higher than the required energy from the actuator, the battery is charged until full capacity. This is detected by the charge controller and further energy supply to the battery is interrupted.

Weather prediction is basically possible in limits and longer bad weather periods can occur in which the solar insolation cannot meet the energy requirements. These fluctuations can be compensated only in limits by the implemented battery

The load conservation during bad weather periods is constituted via so called autonomy days.

Autonomy days are depicted as a fictive period in which the solar system receives no solar energy whatsoever and must still provide the load to 100%. This period can be bridged with full battery without system failure or deep discharge of the battery.

The autonomy days of the solar system are stated in the dimensioning data of the solar system (service handbook).

7.2 Emergency operation in case of system shutdown due to undervoltage

In case the battery is discharged (due to insufficient recharging through the solar system) so far that a switch-off occurs via the battery protection, the load can be operated in the so called emergency mode. By switching off of the fuse F3 and manual toggling of the switch in direction „Emergency ON“ on the battery protector the system is reactivated after switch –off after undervoltage. To operate the actuator in emergency mode, the controller has to be set in such a way that operation of the actuator is possible.



If the battery protector is used as "emergency-on switch" the monitoring electronics of the battery protector is deactivated and the battery can be deeply discharged. However in extreme emergency the chance exists to utilise the battery completely. However it cannot be guaranteed that after the automatic switch-off of the battery protection, the battery can provide the required energy.

If the terminal voltage of the battery has sunk so far that the inverter recognises undervoltage, the battery has to be recharged to be able to operate the actuator. The inverter undervoltage detection is recognisable by the red blinking LED on the underside of the inverter. The undervoltage has to be present for more than 5 seconds, so that the inverter detects the fault.



The inverter resumes operation automatically as soon as the connected voltage is back to normal.

7.3 Procedure in case of system shutdown



It is assumed that the basic planning of the system as also all work concerning transportation, mounting, installation, commissioning, maintenance and repair are performed by qualified personnel resp. are controlled by responsible specialists.

For efficient trouble-shooting please follow the following examinations/checks for system failure from top to bottom.

7.3.1 Check of the fuses (F.) in the switching cabinet.

If a fuse has tripped due to overload or short circuit a defect is present in the circuit of the fuse.

Action:

- Check for manual triggering of the fuse.
- Trouble-shooting in the concerned circuit by a service technician of SIPOS Aktorik, or appropriately trained and qualified specialist.

7.3.2 Check of the RCD switch

If the RCD (Residual Current protective Device) has tripped a residual current is present due to a defect in the circuit after the RCD.

Action:

- Check for manual triggering of the RCD (e.g. pressing the test button).
- Trouble-shooting in the concerned circuit by a service technician of SIPOS Aktorik, or appropriately trained and qualified specialist.

7.3.3 Check in case battery protector has tripped

If the battery protection has triggered due to overvoltage (wrong wiring, lightning strike or defective charge controller) or undervoltage the toggle switch shows in direction „Bord“.

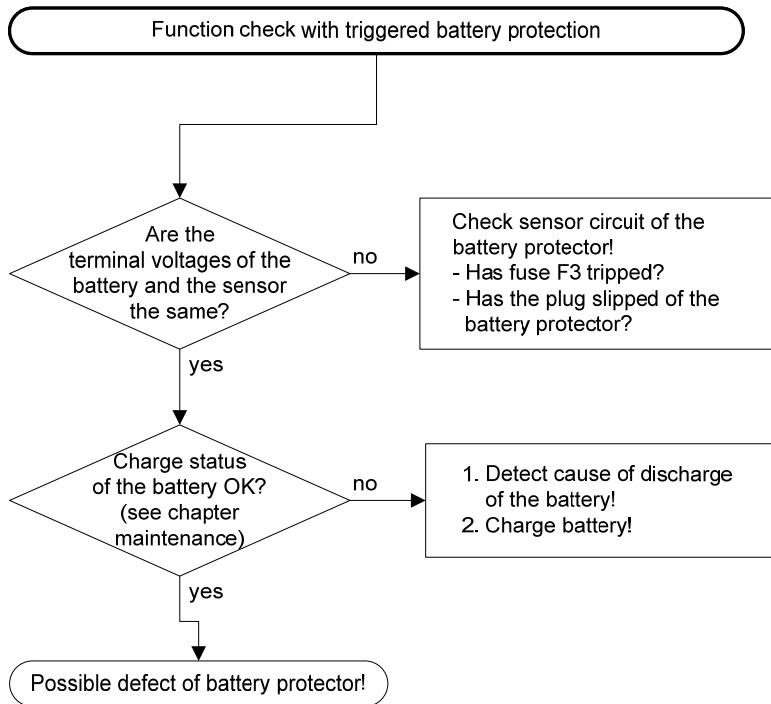

Determination of the cause of battery discharge

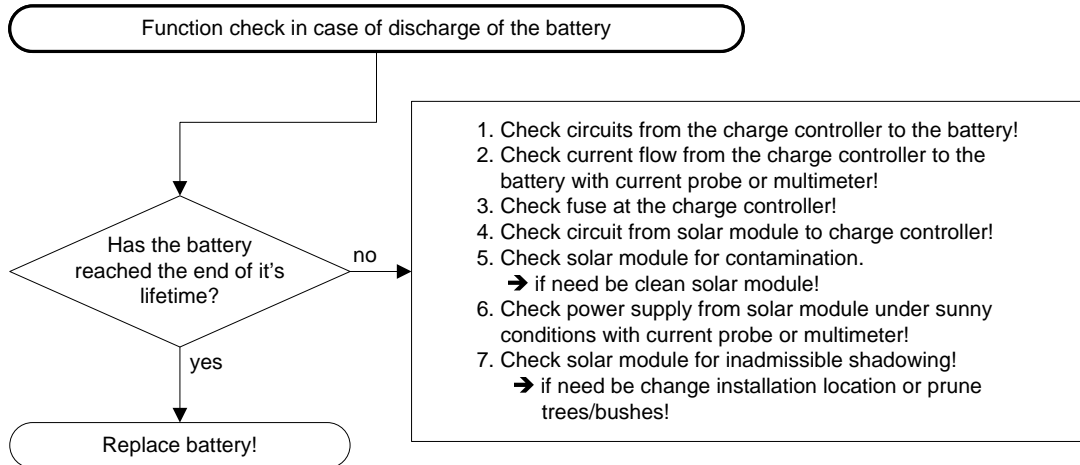

7.3.4 Check in case battery protector has not tripped

In normal operation and for not triggered battery protection the toggle switch shows in direction "ON".

For inspection the power supply to the actuator has to be activated (see supplement instructions "control unit").

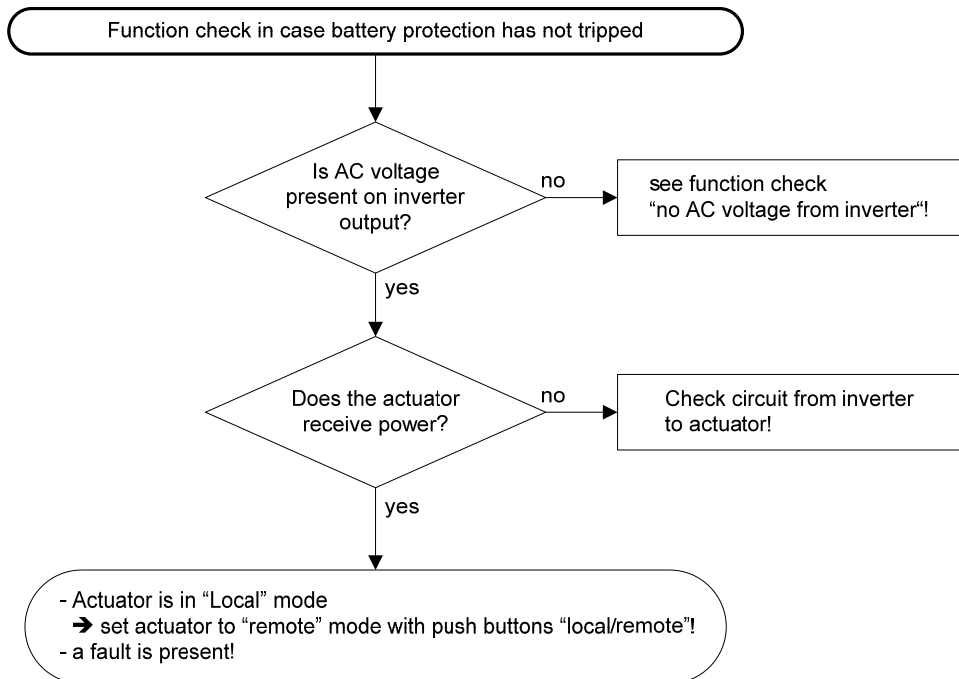

No AC voltage from inverter

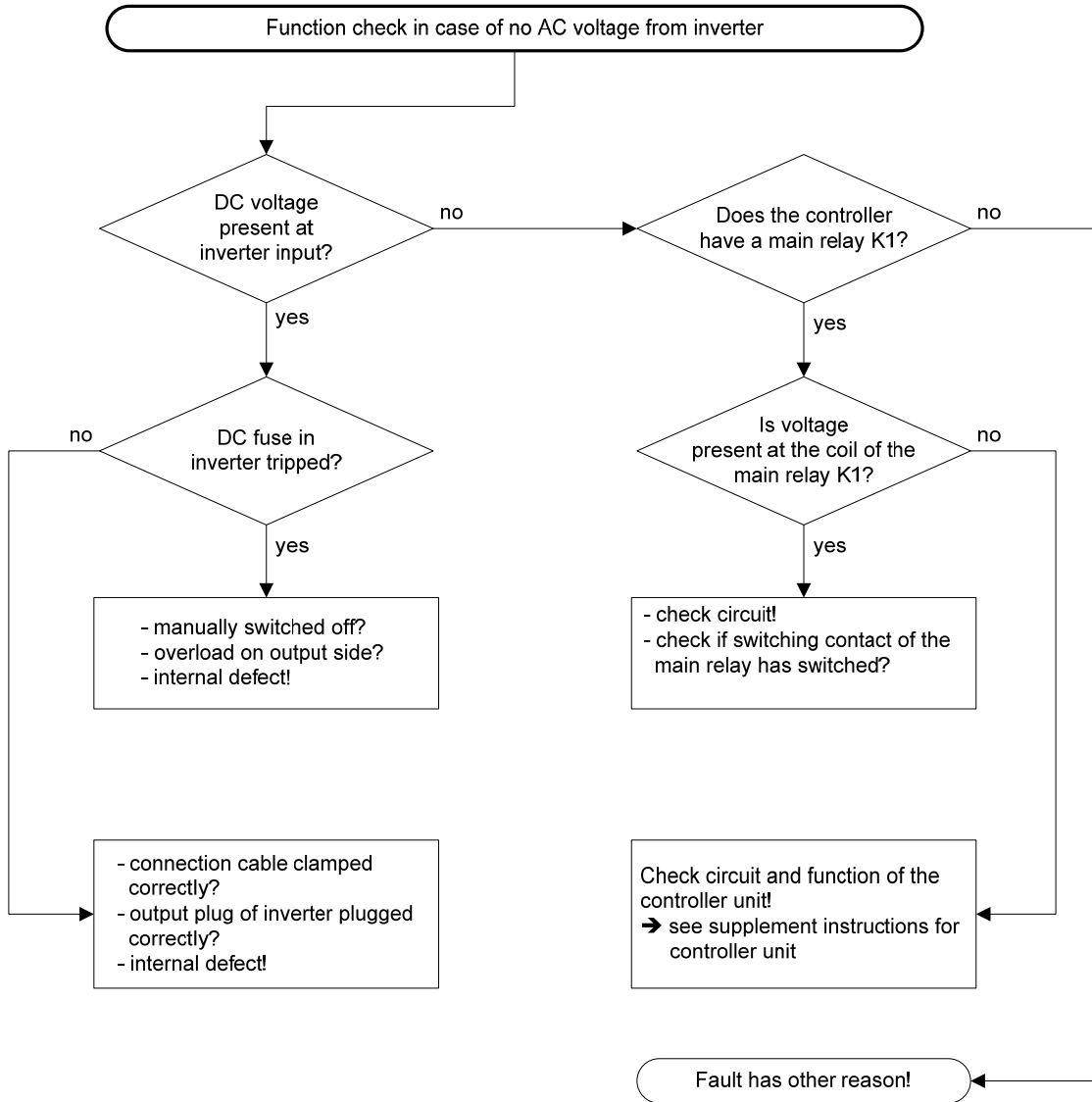

7.4 Cut off in case of emergency

The solar system can be switched off in case of emergency. The cut-off of the load is performed via the battery protector. Manual switch off can be performed by moving the toggle switch in direction "Bord" or by switching off the fuse F3 on the sensor circuit (main switch resp. emergency off function).

In this case the switch on must also be performed manually.

If additionally the continuation of the battery charging is to be inhibited, the fuse F2 must be switched off.

8 Maintenance

The system components of the solar system are maintenance-free with the exception of the actuator, the battery and the solar modules.

The maintenance of the actuator is described in the instruction manual attached to the service handbook.

Measures for maintenance of the battery are described in detail in the chapter "maintenance of the battery".

Cleaning and maintenance of the solar module

Cleaning is normally not necessary for sufficient inclination (larger than 15°) due to self cleaning by rain.

In case of increased pollution that leads to yield loss, cleaning with large quantities of water without cleaning agent and with gentle equipment (sponge) is recommended.

In no case the dirt is to be scratched off dryly or rubbed off, as micro scratches result. We recommend regular inspections.

Additionally in regular periods following sight inspections should be performed.:

- safe fixation of the solar module and corrosion freeness of the mounting parts,
- safe connection, cleanliness and corrosion freeness of all cable connections,
- Integrity of the cables.

